

INSTALLATION GUIDE

Magnetostrictive Sensor Series MSB

For more information please see the data sheet at www.waycon.biz/products/magnetostrictive-transducers/

FIRST STEPS

WayCon Positionsmesstechnik GmbH would like to thank you for the trust you have placed in us and our products. This manual will make you familiar with the installation and operation of our magnetostrictive sensors. Please read this manual carefully before initial operation!

Unpacking and checking:

Carefully lift the device out of the box by grabbing the housing. After unpacking the device, check it for any visible damage as a result of rough handling during the shipment. Check the delivery for completeness. If necessary consult the transportation company, or contact WayCon directly.

MOUNTING INSIDE A CYLINDER

The cylinder head (in which the threaded hole will be drilled for inserting the transducer) must be made of non-magnetic material. The residual magnetization caused by drilling the threaded hole must be less than 4 Gauss.

MSB...F1

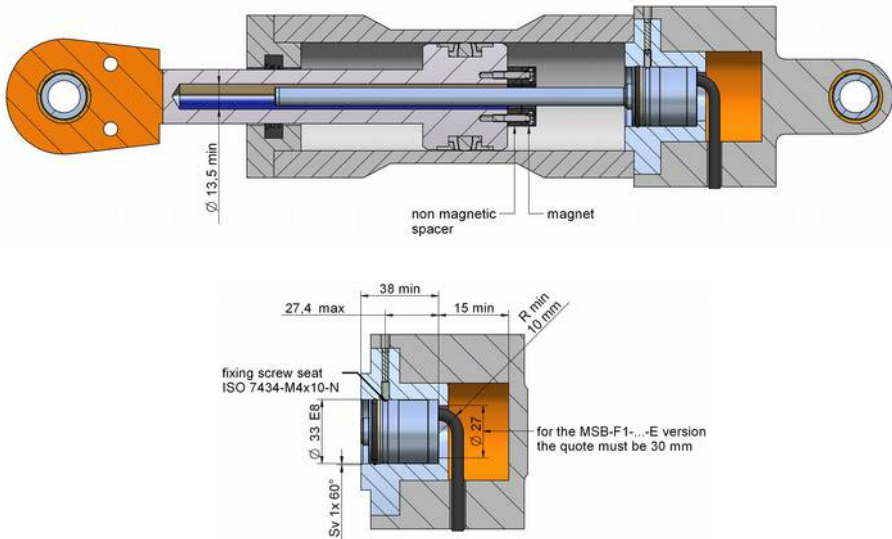

WayCon

Positionsmesstechnik

INSTALLATION GUIDE

Magnetostrictive Sensor Series MSB

For more information please see the data sheet at www.waycon.biz/products/magnetostrictive-transducers/

MOUNTING INSIDE A CYLINDER

MSB...F2:

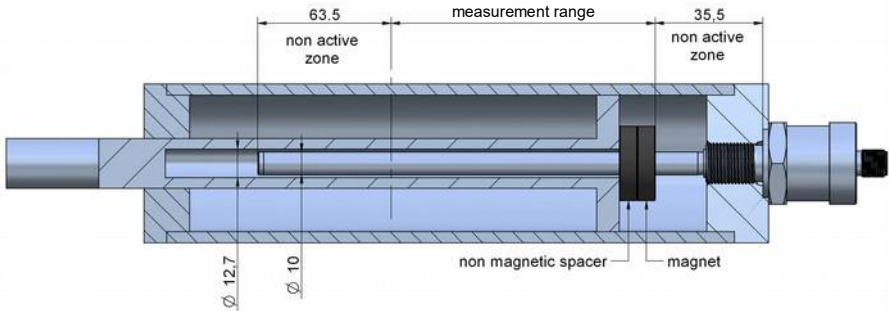

Thread M18x1,5

The sealing surface must be free from scratches longitudinal or spiral.

Ro 1.6 μm for sealing with NON-pulsating pressure

Ro 0.8 μm for seals with pulsating pressure

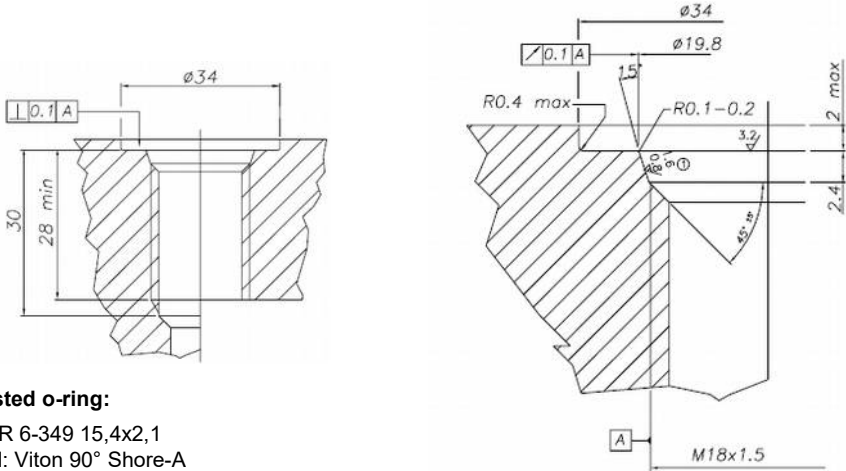

Suggested o-ring:

PARKER 6-349 15,4x2,1

Material: Viton 90° Shore-A

Mixes: PARKER N552-90



TECHNICAL DRAWING

MSB...F1

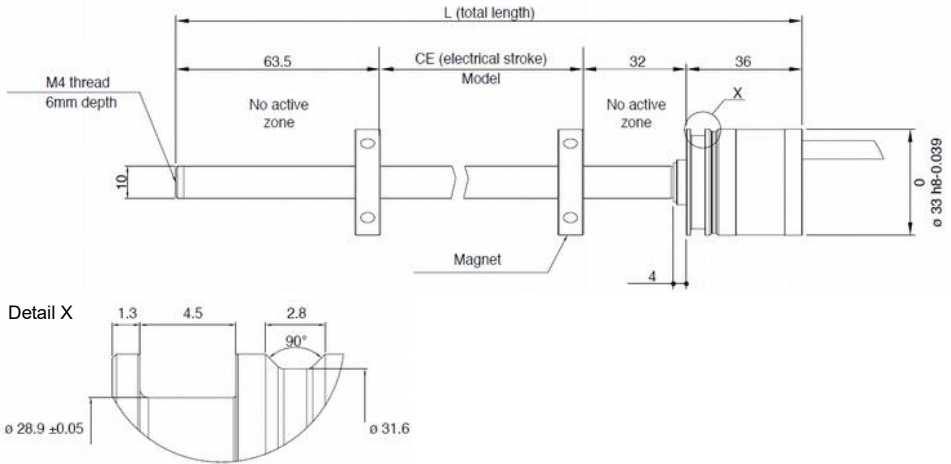

MSB...F2

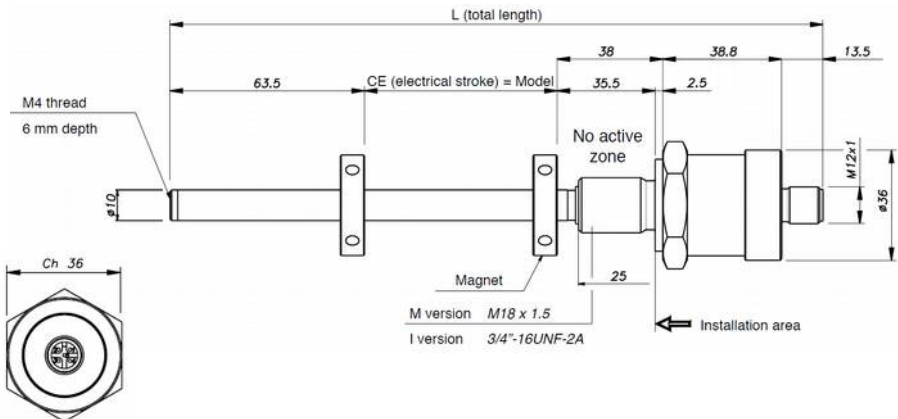

INSTALLATION GUIDE

Magnetostrictive Sensor Series MSB

For more information please see the data sheet at www.waycon.biz/products/magnetostrictive-transducers/

ELECTRICAL CONNECTION

- The transducer must be installed in a grounded metallic cylinder.
- The braiding of the shielded transducer connection cable must be connected to the case of the female connector so that the shielding is connected to the transducer case.
- The cable shielding on PLC side must be isolated.
- If the transducer is installed in a cylinder isolated from the ground, the cable shielding on PLC side must be grounded.
- The transducer must be installed away from sources of magnetic fields, both static and 50 Hz (electric motors, solenoids, etc.).
- The 24 VDC feed must be dedicated to the transducers or must be drawn directly from the power terminals and as near as possible.
- The sensors must be powered with non-distributed networks and always at lengths of less than 30 m.
- The magnetic cursor must be installed by placing a non-magnetic spacer (made of brass, aluminium, stainless steel or plastic) between the piston surface and the cursor.

Standard Installation (recommended)

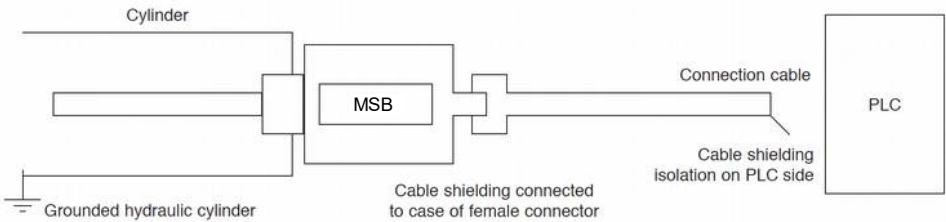

ELECTRICAL CONNECTION MSB...N/K/E-F1

| MSB...N-F1 | MSB...K-F1 | MSB...E-F1 | Cable |
|------------------|------------------|------------------|--------|
| 0.1...10.1 V | 0.1...5.1 V | 4...20 mA | yellow |
| Output GND | Output GND | Output GND | pink |
| Power Supply + | Power Supply + | Power Supply + | brown |
| Power Supply GND | Power Supply GND | Power Supply GND | blue |



ELECTRICAL CONNECTION MSB...S-F1

| MSB...S-F1 | Cable |
|------------------|--------|
| Output + | grey |
| Output - | green |
| Input + | yellow |
| Input - | pink |
| Power Supply + | brown |
| Power Supply GND | blue |

In case of cable length shortening, after cutting the cable take care of soldering and insulating the green and grey wires together

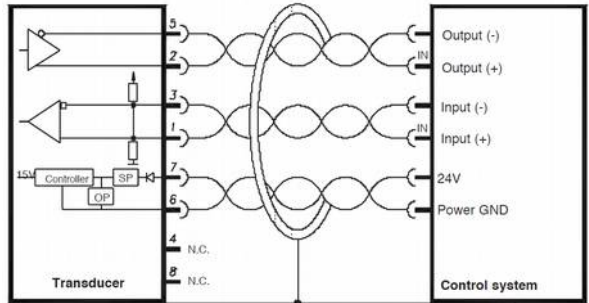

DIGITAL OUTPUT MSB...S-F1

Series MSB... -S magnetostrictive transducers supply digital outputs in START/STOP format with RS422 differential serial transmission. The transducer requests an initialisation pulse that launches sampling. The following pulses are transmitted on the outputs:

Start: the initialisation pulse retransmitted

Stop: the pulse corresponding to the position of each magnet.

The time between the Start pulse and the subsequent Stop pulses is proportional to the position of each magnet according to the "magnetostrictive wave propagation speed" constant, equal to about 2900 m/sec.

$$P = \text{Time} * 2900 \text{ m/sec}$$

The correct propagation speed for each product is shown on the product label.

Resolution in terms of metres is linked to the resolution used to measure time

$$1 \mu\text{Sec} (1 \text{ MHz}) \Rightarrow 2.9 \text{ mm}$$

$$10 \text{ nSec} (100 \text{ MHz}) \Rightarrow 0.029 \text{ mm}$$

$$1 \text{ nSec} (1 \text{ GHz}) \Rightarrow 2.9 \mu\text{m}$$

The measurement reference is the leading edge of the pulse. Optimum width of the interrogation pulse is 3 μsec , but the transducer works correctly for times from 1.5 to 5 μsec .

INSTALLATION GUIDE

Magnetostrictive Sensor Series MSB

For more information please see the data sheet at www.waycon.biz/products/magnetostrictive-transducers/

DIGITAL OUTPUT MSB...S-F1

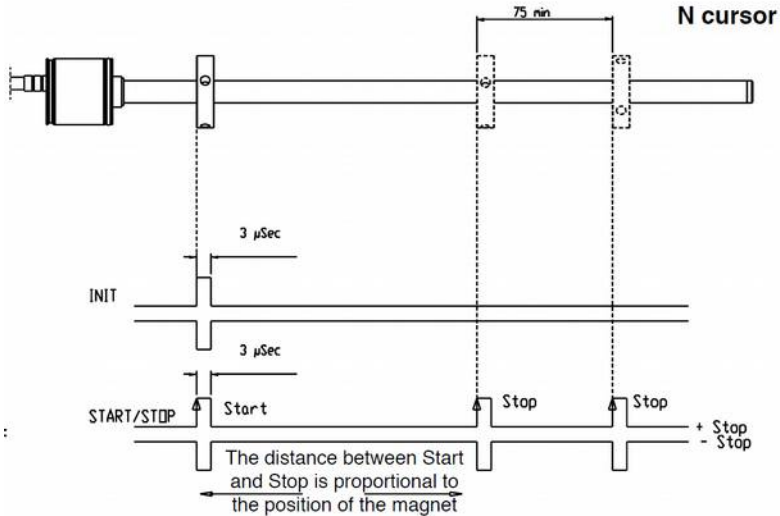

ELECTRICAL CONNECTION MSB...F2

| MSB...N-F2 | MSB...K-F2 | MSB...E-F2 | PIN |
|------------------|------------------|------------------|-----|
| 0.1...10.1 V | 0.1...5.1 V | 4...20 mA | 1 |
| Output GND | Output GND | Output GND | 2 |
| DO NOT CONNECT | DO NOT CONNECT | DO NOT CONNECT | 3 |
| Power Supply GND | Power Supply GND | Power Supply GND | 4 |
| Power Supply + | Power Supply + | Power Supply + | 5 |

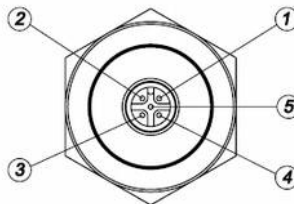

Connector output M12
MSB...F2



MAGNETIC CURSOR

Please order magnetic cursor separately (not included in the delivery of the sensor).

| Order Code | A | B | C | D |
|---------------------|------|------|------|------|
| PCUR022 | 32.8 | 13.5 | 23.9 | - |
| PCUR023 | 32.8 | 13.5 | 23.9 | 11.0 |
| PCUR024 | 25.4 | 13.5 | - | - |
| PCUR026 for liquids | 52.4 | 12.0 | 44.0 | - |
| PCUR027 for liquids | 52.4 | 15.0 | 44.0 | - |

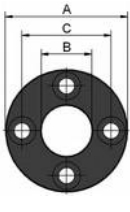

PCUR022

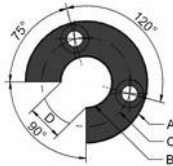

PCUR023

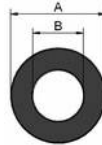

PCUR024

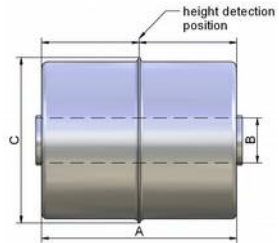

PCUR026/027

Note:

PCUR026 and PCUR027 are supplied with kit PKIT036 for floating cursor for liquids.
Material PCUR026, PCUR027: stainless steel AISI 316

TECHNICAL DATA

| | | |
|--------------------------|--------|--|
| Electrical stroke (C.E.) | [mm] | Measurement range |
| Linearity | | < ±0.02 (min. ±0.06 mm) |
| MSB...F1 total length L | [mm] | Measurement range + 131.5 (excluding cable) |
| MSB...F2 total length L | [mm] | Measurement range + 140.3 (excluding connector) |
| Repeatability | [mm] | < 0.01 |
| Hysteresis | | < ±0.005 % |
| Sampling time | [msec] | MR 50 to 1000: 1 / MR 1100 to 2000: 1.5 / MR > 2000: 2 |

MR: Measurement range



ACCESSORIES MSB...F2

Connection cable analog output, 5-pole, s shielded

K5P2M-S-M12 2 m, connector, straight

K5P5M-S-M12 5 m, connector, straight

K5P10M-S-M12 10 m, connector, straight

K5P2M-SW-M12 2 m, connector, angular

K5P5M-SW-M12 5 m, connector, angular

K5P10M-SW-M12 10 m, connector, angular



| PIN | Cable colour K5P.. |
|-----|--------------------|
| 1 | brow n |
| 2 | w hite |
| 3 | blue |
| 4 | black |
| 5 | grey |

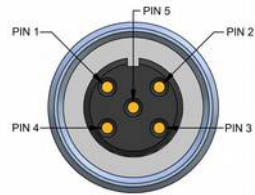

DECLARATION OF EC-CONFORMITY

WayCon Positionsmesstechnik GmbH
Mehlbeerenstrasse 4
82024 Taufkirchen / Germany

Classification
Series

This is to certify that the products
Magnetostrictive Sensors
MSB

fulfill the current request of the following EC-directives:

EMV-directive 2004/108/EU (until April 19th, 2016)

2014/30/EU (from April 20th, 2016)

applied harmonized standards:

EN 61000-6-2:2005, EN 61000-6-4:2007, EN 61326-1:2006

The declaration of conformity loses its validity if the product is misused or modified without proper authorisation.

Taufkirchen, 24.02.2016

Andreas Täger, CEO